

Vertical Form-Fill-Seal AUGER FILLERS

SPECIFYING INFORMATION	
VFFS (Manufacturer, Model): _____	
Product: _____	
Amount of Fill: _____	
Pouch Size: _____	
Production Rate: _____	
Accuracy: _____	
Funnel Depth: _____	
Forming Tube I.D.: _____	
Collector Funnel Height: _____	
<i>Collector Funnel Diameter</i>	<i>"A"</i>
6"	13" minimum
8"	16" minimum
10"	17" minimum

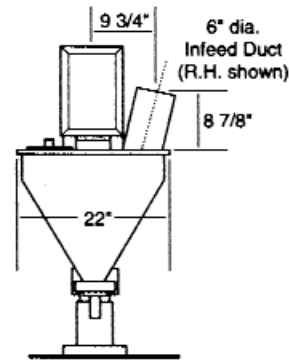
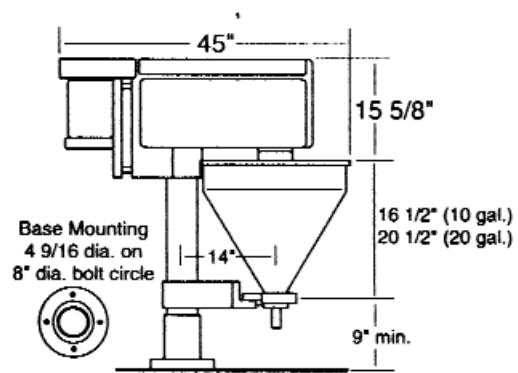

FREE FLOW ASSEMBLY
(Granular Products)

NON-FREE FLOW ASSEMBLY
(Powder Products)

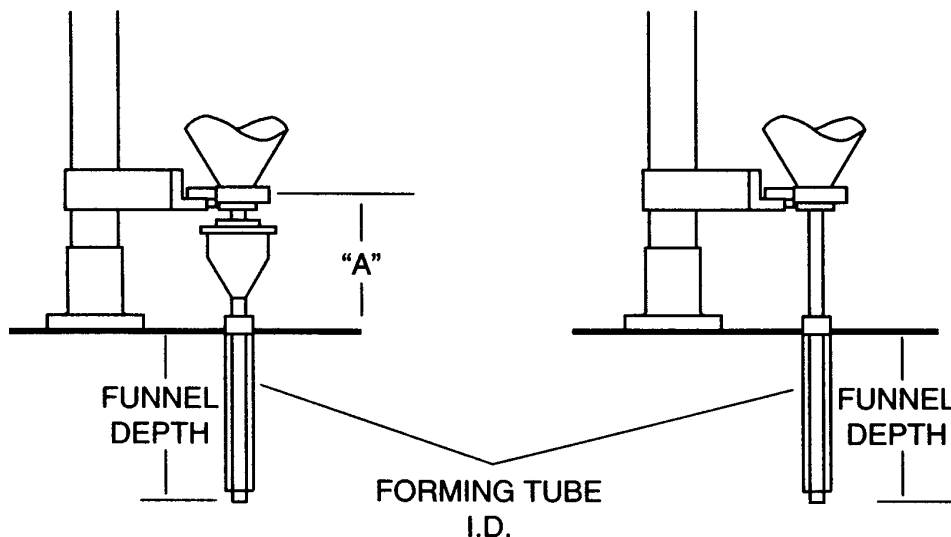

In addition to the supply of augers, funnels, and other accessories; AUGER FABRICATION can supply complete auger filling assemblies for use with Vertical Form-Fill-Seal (VFFS) equipment. AUGER FABRICATION's extensive experience in this field can accommodate all types and configurations of VFFS machines.

Use this page to specify an auger filling assembly for your equipment. Additional details or other, special requirements can be sketched on the worksheets at the end of this catalog.

